



HIGH-PRECISION, HIGH-PRODUCTIVITY
LARGE SIZE MULTI-TASKING TURNING CENTER

SMX

5100L/LB/LS/LSB/XL/XLB



SMX 5100 SERIES

SMX 5100 series is large capacity, (up to 4 metre maximum turning length), multi-tasking turning centers equipped with high power/torque spindles and wide machining areas. The machines are ideal for the complex mill-turn machining of long and large-diameter workpieces typically found in the oil and gas, aerospace, large automotive sectors. SMX 5100 feature thermal compensation systems that minimize thermal deformation and deliver consistently high precision. The machines' ergonomic design, that has taken into account operator convenience and efficient maintenance, provides an optimal solution that meets every customer's requirements.





HIGHER PRODUCTIVITY THROUGH POWERFUL MULTI-TASKING FUNCTIONS

- Complex machining capabilities of left spindle, right spindle, B-axis, milling spindle
- Built-in spindle/high-torque Big bore spindle can be selected according to customer's machining conditions and needs
- High-rigidity machine construction using structural analysis design
- Maximized Y-axis machining area through orthogonal design structure

ENHANCED PRECISION THROUGH HIGH ACCURACY CONTROL FUNCTIONS

- Minimized thermal deformation of the spindle and feed axis using oil cooler
- Adoption of roller LM guideways with high rigidity and high precision
- Equipped with 0.0001° B-axis and C-axis accuracy control function

EASY AND CONVENIENT OPERATION THROUGH AN ERGONOMIC DESIGN

- CUFOS CNC with CPS(Collision protection system), Tool management and additional customized functions
- Wide door and easy spindle accessibility for convenient workpiece loading/unloading
- Side-to-side movable swiveling operation panel with adjustable height
- Convenient ATC operation panel

BASIC STRUCTURE

Optimized orthogonal structure secures a wide working area, easy operation and stability for high precision machining.

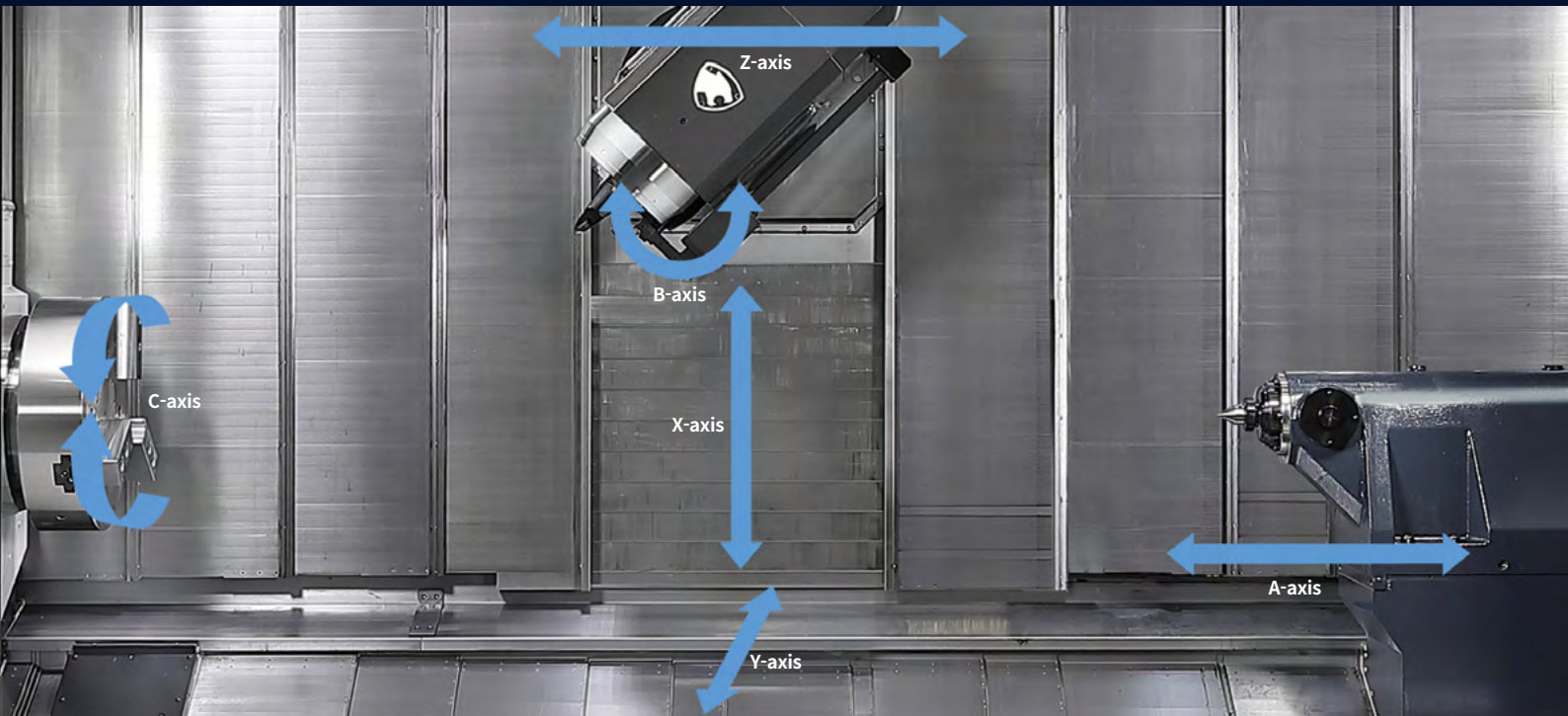

Travel

SMX 5100L/LB/LS/LSB

X-axis **910(-30/+880)** mm
35(-1.2/+34.6) inch

Y-axis **520(±260)** mm
20.5(±10.2) inch

Z-axis **3215** mm 126.6 inch

A-axis* **3100** mm 122.0 inch

B-axis **240(±120)°**

SMX 5100XL/XLB * Tailstock/Right Spindle travel

Z-axis **4215** mm A-axis* **4100** mm
165.9 inch 161.4 inch

Rapid traverse rate

| | SMX 5100L/LB | SMX 5100LS/LSB | SMX 5100XL/XLB |
|---------|-----------------------|----------------------|-----------------------|
| X-axis | 40 m/min (1574.8 ipm) | | |
| Y-axis | 40 m/min (1574.8 ipm) | | |
| Z-axis | 40 m/min (1574.8 ipm) | | 30 m/min (1181.1 ipm) |
| A-axis* | - | 14 m/min (551.2 ipm) | - |
| B-axis | 30 r/min (1181.1 ipm) | | |

Robust design

FEM (Finite Element Method) analysis results in superior machine stability. All guideways are sealed with protective covers. This prevents hot chips and coolant from contacting the guideways, thereby maintaining long-term accuracy.

Feed axis

Best-in-class X-axis travel (910mm) and Y-axis travel (520mm), in addition to the machine's orthogonal design and linear drives deliver speed, precision and flexibility.

High precision roller-type LM guideways

High precision roller type LM guideways minimize non-cutting time through high rapid rates.

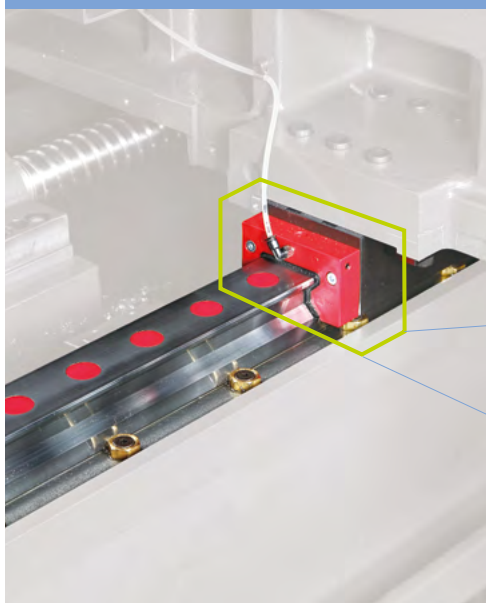

COOLING CONCEPT MAINTAINS HIGH ACCURACY OVER LONG MACHINING RUNS

Design and structure reduces thermal error and ensures superior accuracy over long machining runs

Minimization of thermal deformation by oil cooling

Spindle and ball screw core cooling system minimizes thermal deformation during long machining processes and enhances high accuracy performance.

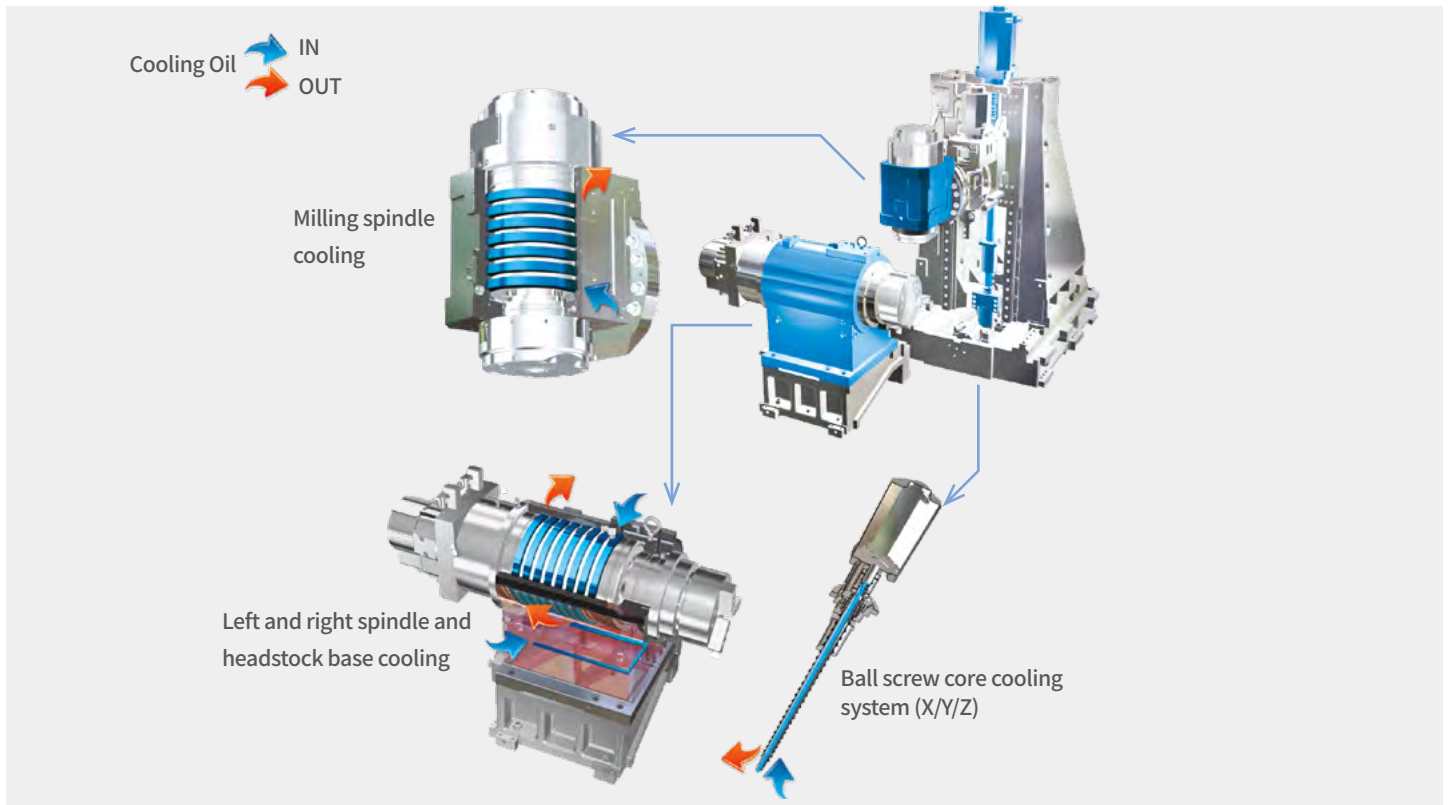

Roundness and surface roughness

By systematically testing individual machine elements and analysing the results, the SMX 5100 series is able to deliver precision and reliability, and high levels of customer satisfaction.

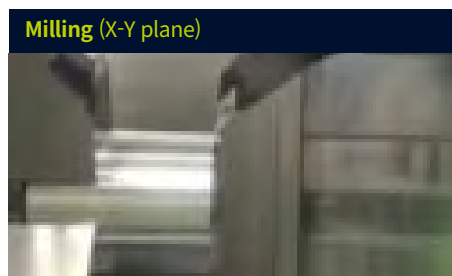
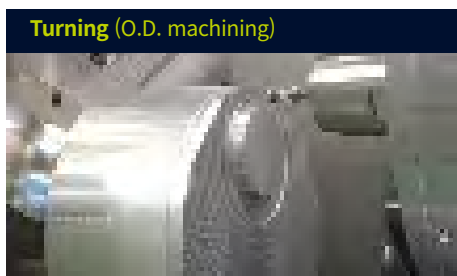

** This test is performed in a DN Solutions's test environment.*

Roundness

5 μm

| | |
|----------------------|--|
| Material | Aluminium |
| Tool | Endmill \varnothing 10 mm (TAEGUTEC) |
| Spindle speed | 12000 r/min |
| Feedrate | 300 mm/min |

Roundness

0.39 μm

| | |
|----------------------|-------------------|
| Material | Aluminium |
| Tool | OD tool (SANDVIK) |
| Spindle speed | 1000 r/min |
| Feedrate | 0.1 mm/rev |

Roundness

1.25 μm

| | |
|----------------------|-------------------|
| Material | Aluminium |
| Tool | OD tool (SANDVIK) |
| Spindle speed | 1500 r/min |
| Feedrate | 0.1 mm/rev |

MACHINING AREA

Orthogonal structure increases machining capacity and the extended turning diameter enables the machining of large size workpieces.

Maximized Y-axis machining area through orthogonal structure design

Maximized Y-axis machining area due to the orthogonal design structure enables the machining of a wide range of workpieces.

Y-axis machining area

520 mm
20.5 inch



Gear skiving solutions

We can help manufacturers dramatically improve their productivity with gear machining solutions such as power skiving, invo-milling and hobbing: all of which enable high-precision external / internal gear machining in a single setup.

** Please contact DN Solutions for further information.*



Max. machining diameter

830 mm
32.7 inch

Max. machining length

| SMX 5100L/LB/LS/LSB | SMX 5100XL/XLB |
|------------------------------|------------------------------|
| 3050 mm 120.1 inch | 4070 mm 160.2 inch |

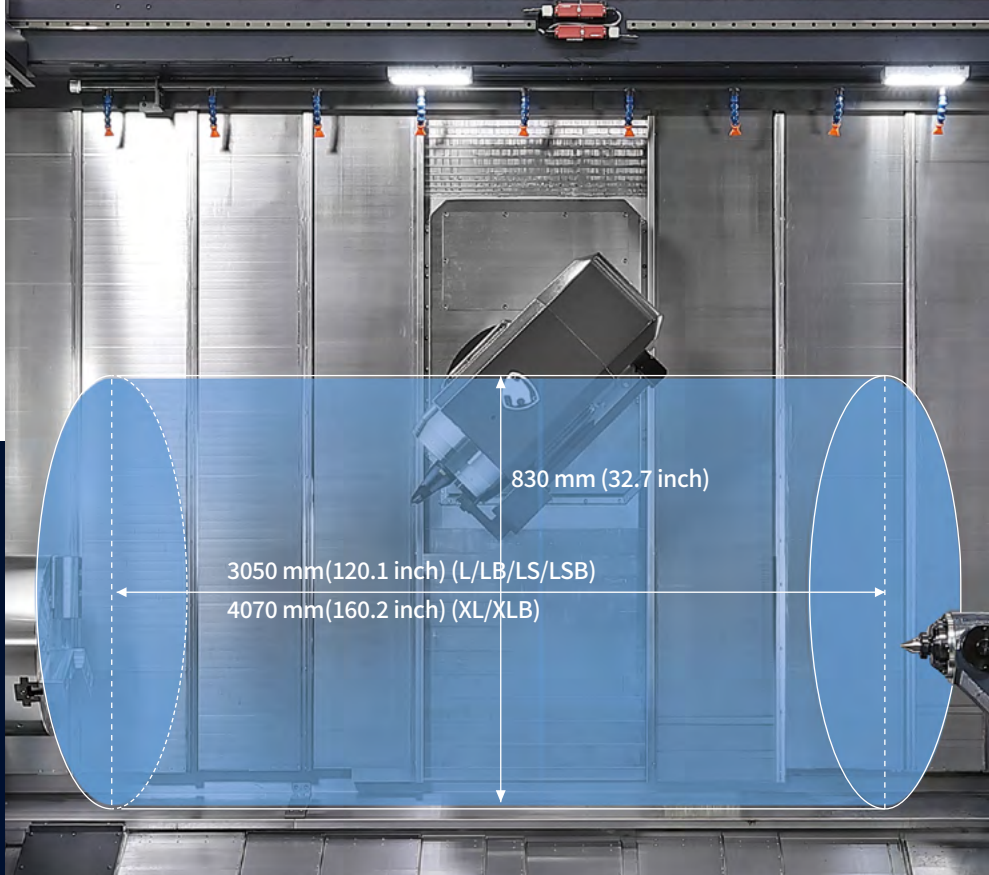

Extended machining area

The extended machining area allows for the machining of large diameter workpieces up to 4 metres in length.

CUTTING PERFORMANCE

Powerful and fast machining capability across turning, milling, drilling, tapping and other multi-tasking operations ensures higher productivity and efficiency.

Powerful machining

O.D. cutting

| Spindle speed r/min | Cutting speed m/min (ipm) | Feedrate mm/rev | Radial cutting depth mm (inch) | Material removal rate cm ³ /min (inch ³ /min) |
|------------------------|------------------------------|--------------------|-----------------------------------|--|
| 253 | 210 (8267.7) | 0.55 (0.0) | 8.5 (0.3) | 1405 (85.7) |

U-drill (milling)

| Tool mm (inch) | Spindle speed r/min | Feedrate mm/min (ipm) | Material removal rate cm ³ /min (inch ³ /min) |
|-------------------|------------------------|--------------------------|--|
| Ø80 (Ø3.1) | 796 | 200 (7.9) | 600 (36.6) |

Face milling

| Tool mm (inch) | Milling spindle speed r/min | Radial cutting depth mm (inch) | Feedrate mm/min (ipm) | Material removal rate cm ³ /min (inch ³ /min) |
|-------------------|--------------------------------|-----------------------------------|--------------------------|--|
| Ø100 (Ø3.9) | 637 | 7 (0.3) | 1114 (43.9) | 602 (36.7) |

End milling

| Tool mm (inch) | Milling spindle speed r/min | Radial cutting depth mm (inch) | Feedrate mm/min (ipm) | Material removal rate cm ³ /min (inch ³ /min) |
|-------------------|--------------------------------|-----------------------------------|--------------------------|--|
| Ø32 (Ø1.3) | 597 | 32 (1.3) | 350 (13.8) | 358 (21.8) |

Tapping

| Tool mm (inch) | Milling spindle speed r/min | Feedrate mm/min (ipm) |
|--------------------------|--------------------------------|--------------------------|
| M36 x P4.0 (M1.4 x P0.2) | 221 | 4.0 (0.2) |

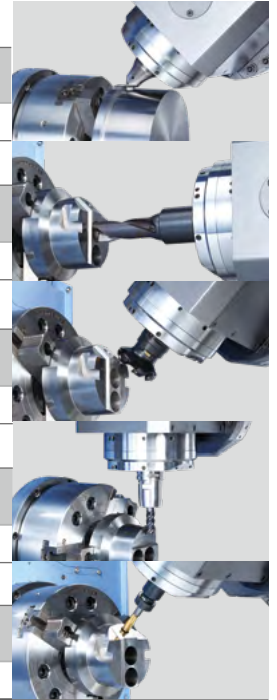

* The results (above) are provided as examples. Differences in cutting and environmental conditions will deliver different results.

Higher productivity by multi-tasking performance

Faster machining times compared to working with many conventional machines provides superior productivity and machining capability.

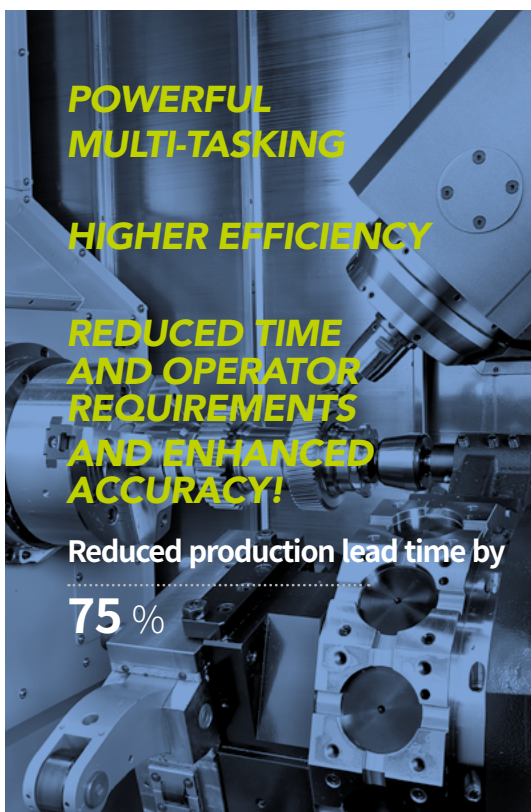

Conventional machining process



Three machines

SMX process



One machine



Three operators



One operator



One machine setup → Move workpiece → Another machine setup
→ Move workpiece → Another machine setup



One machine setup



Floor space for at least three machines required



Floor space for only one machine

SPINDLE

Built-in spindle or high-torque big-bore spindle can be selected depending on machining conditions: for example - a) high-precision 5-axis contouring and b) heavy-duty machining of difficult-to-machine materials.

Milling spindle

10000 r/min

37 kW
49.6 hp

Tool shank of milling spindle

Coromant Capto® C8

OPTION HSK 100T

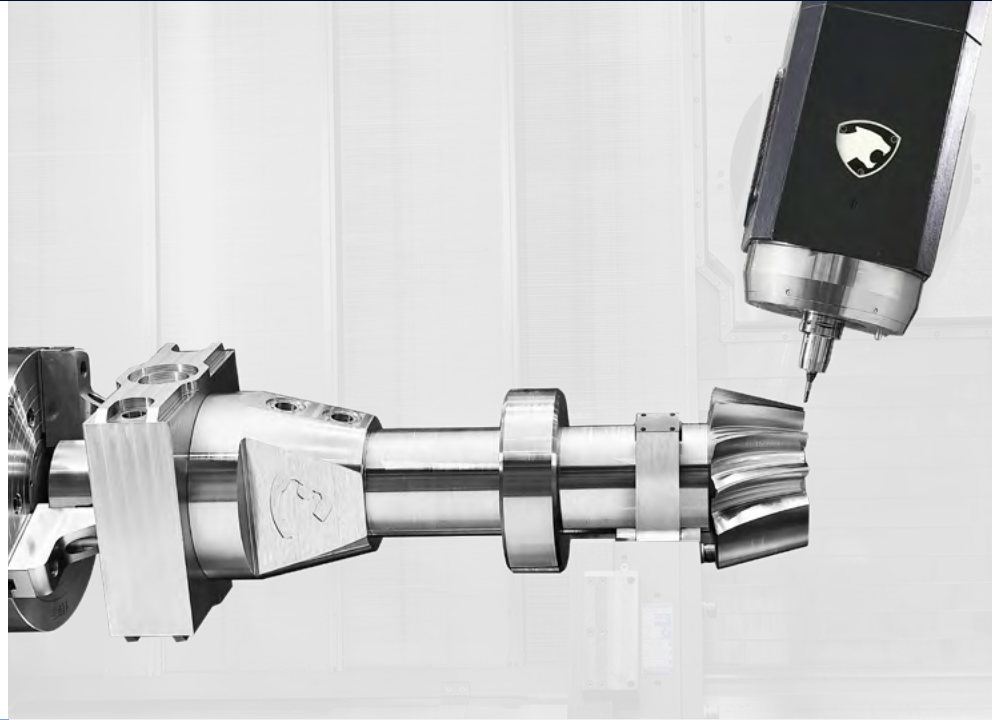

Perfect combination of rotating spindles

Both left and right spindles are capable of high-accuracy C-axis operation and, with the milling spindle, can perform various machining functions like turning, milling and synchronized cutting in a single set up.

5-axis
Contouring

Aerospace,
Precision
machinery

Heavy-duty
cutting
difficult-to-
machine
materials

Oil/energy,
General
machinery

Built-in spindle

SMX 5100L/LS/XL
15" chuck, 18" chuck OPTION

High-torque big-bore spindle

SMX 5100LB/LSB/XLB
21" chuck, 24" chuck OPTION

| Model | Spindle | Standard Chuck inch | Spindle speed r/min | Power kW (Hp) | Torque N · m (ft-lbs) | Condition |
|--------------------|---------------|------------------------|------------------------|----------------------|--------------------------|-------------|
| SMX 5100L/LS/XL | Left spindle | 15 | 2400 | 37/30 (49.6/40.2) | 1643 (1212.5) | 30min/cont. |
| SMX 5100LB/LSB/XLB | | 21 | 1500 | | 4200 (3099.6) | |
| SMX 5100LS | Right spindle | 15 | 2400 | | 1643 (1212.5) | |
| SMX 5100LSB | | 21 | 1500 | | 4200 (3099.6) | |

| Model | Spindle | Standard Chuck inch | Spindle speed r/min | Power kW (Hp) | Torque N · m (ft-lbs) | Condition |
|--------------------|-----------------|------------------------|------------------------|------------------------------|--------------------------|------------------------|
| SMX 5100L/LS/XL | Milling spindle | CAPTO C8 | 10000 | 37/30/25 (49.6/40.2/33.5) | 302 (222.9) | 2.5min/ 30min/cont. |
| SMX 5100LB/LSB/XLB | | | | | | |

SPINDLE | TAILSTOCK

Machining all angles (C & B-axis)

Machining is mainly done with the Left and Milling spindles. The C-axis of the left spindle and B-axis of the milling spindle, with Y-axis control, create a multi-tasking turning center that can drill, tap and end mill in any angle as well as machine contours to high precision. (5-axis simultaneous machining is an option).

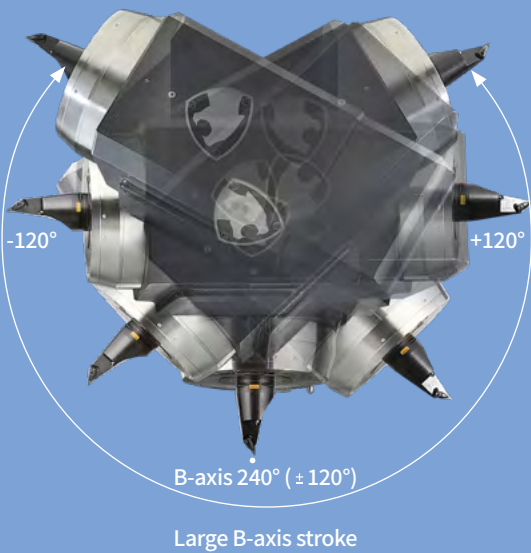

Left/Right spindle

0.0001°

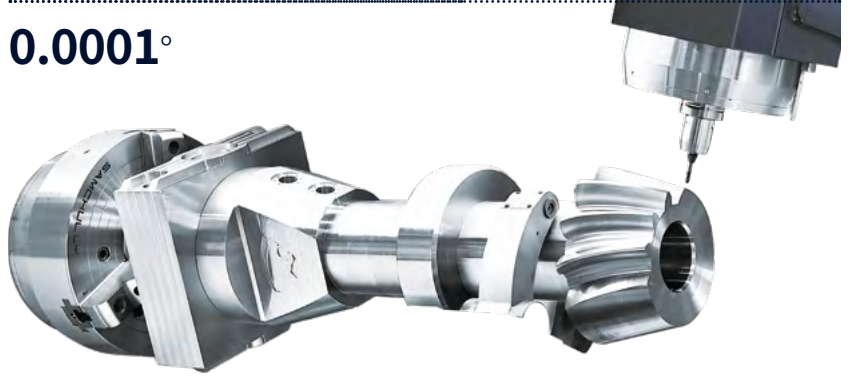

• C-axis positioning control

To enhance C-axis positional accuracy of the left spindle, a position compensation sensor has been adopted. Left and Right spindles can have C-axis positioning control over every 0.0001° in 360°.

• B-axis positioning control precise continuous indexing

B-axis indexing movement every 0.0001° in ±120° enables not just horizontal front face machining but also complex angular machining too.

• Emergency braking function

In case of non-scheduled stoppages caused by power outages etc., the braking function protects operators and workpieces.



Swivel and indexing of the B-axis is driven by a servo motor and a roller gear cam, ensuring sufficient rigidity for powerful cutting as well as for high-precision positional control.

Tailstock

Easier and faster set-up of the tailstock using M-code program can be achieved.

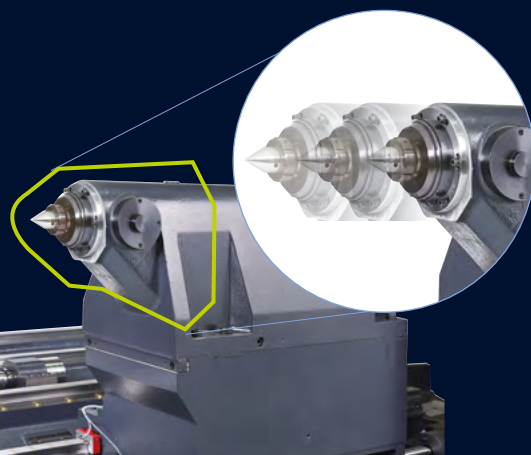

Servo driven tailstock

The operator inputs the correct M-code information in the control and the tailstock moves to its proper position automatically through the linear motion control of the servo motor and ball screw. This delivers improved efficiency by reducing set-up times and non-cutting times.

| Model | Tail stock travel mm (inch) | Max. quill thrust force kN | Tail stock center |
|----------------|--------------------------------|----------------------------------|--|
| SMX 5100L | 3100 (122.0) | 15 | MT#5 (Built-in type Dead Center) |
| SMX 5100LB | 3100 (122.0) | 20 | |
| SMX 5100XL/XLB | 4100 (161.4) | 24 | MT#6 (Built-in type Dead Center) |

AUTOMATIC TOOL CHANGER

Servo ATC and servo tool magazine ensuring fast and reliable tool indexing.

Tool storage

40 tools OPTION **80/120** tools

Max. tool length (from gauge line)

600 mm
23.6 inch

Max. tool weight

30 kg
66.1 lb

Max. tool moment

29.4 N·m
21.7 ft-lbs

Max. tool diameter (continuous)

Ø135 mm
5.3 inch

Max. tool diameter (adjacent pots are empty)

Ø260 mm
10.2 inch

Enlarged touch screen panel is available as an option

10.4 inch

Servo driven ATC & Tool magazine

The tool magazine capacity can be increased to 120 tools. Tools are selected by the fixed address method that helps reduce changeover times.

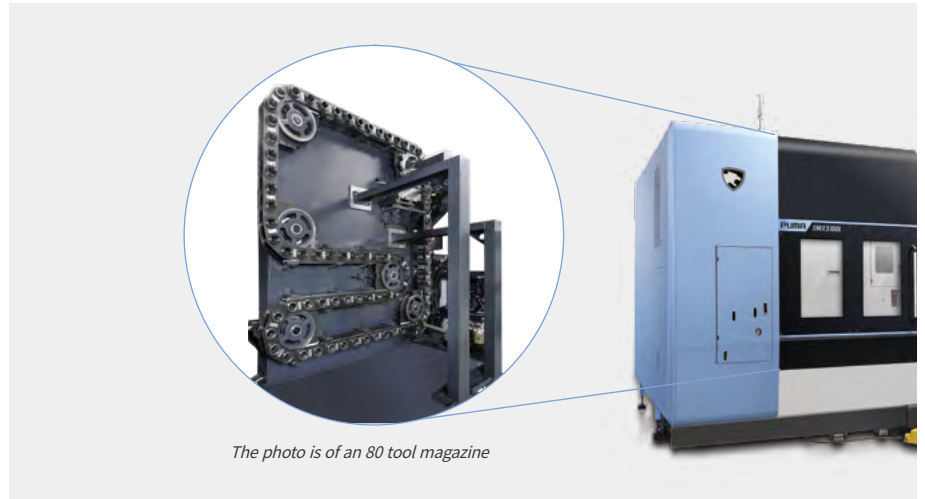

The photo is of an 80 tool magazine

ATC operation panel

The status of the ATC and the tool magazine unit can be seen, reviewed and monitored via the touchscreen. The touchscreen is used to operate the ATC, the tool magazine and the tool pot carrier.



ATC magazine information display

The operational status of the ATC magazine, which is difficult to check from outside, can be seen at a glance on 10.4" big screen .

Convenient touchscreen operation

Available buttons are activated according to current and next step operations. In this way complex manual operations are undertaken logically and easily.

Tool magazine monitoring

Tool magazine status can be monitored in real time by a CCTV installed inside the magazine.

ADDITIONAL TOOL MAGAZINE

Optional LBB (Long boring bar) and long tool magazines can enable fast and efficient ID turning and milling of long pipes, tubes and shafts.

Automatic LBB changer package & long tool magazine OPTION

SMX 5100L/LS machines can accommodate workpieces up to 3050mm in length and can machine long tubes such as isolation valves/ pipe lines (Oil/Gas) and landing gear axles (Aerospace) that require center bores. Additional (Optional) Long boring bar/Long tool magazine can reduce machining processes/ cycle times and improve machining capability.

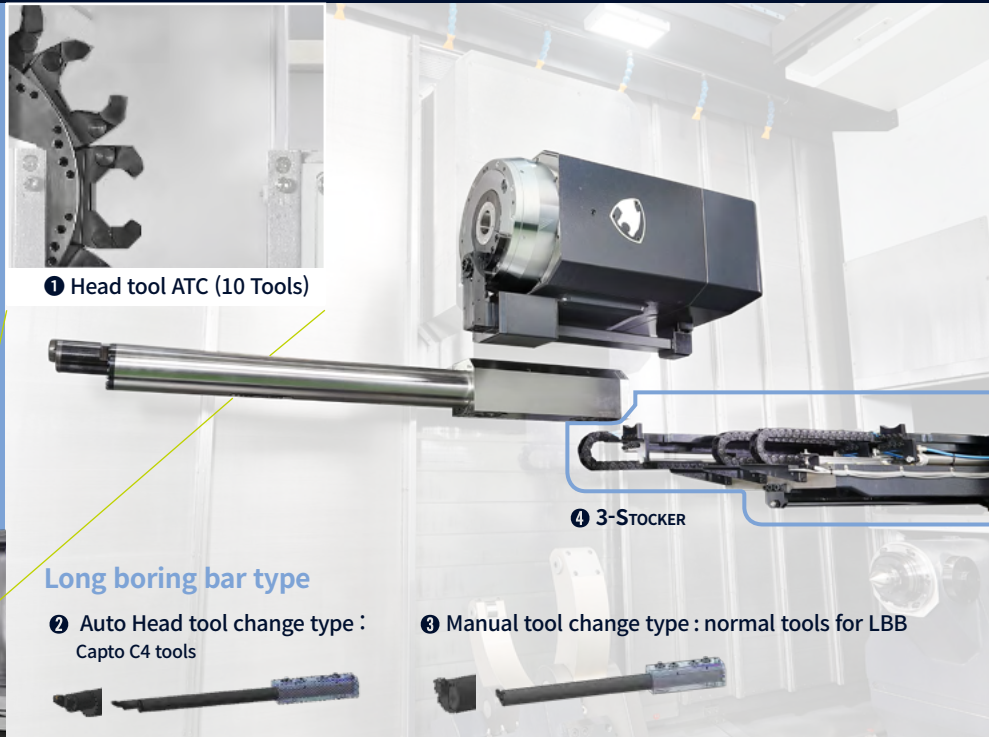

Max. LBB size

Ø100 x L1000 mm
Ø3.9 X 39.4 inch

Max. weight

140 kg
308.6 lb

LBB storage

Max **3** ea

Max. tool size

Ø80 x L1120 mm
Ø3.1 x L 44.1 inch

Max. weight

70 kg
154.3 lb

Tool storage

4 tools

Automatic LBB changer package OPTION SMX 5100L/LB/XL/XLB

| Package name | Composition | | |
|------------------------|------------------------------|---------------------------------|----------------------------------|
| Package A1* (1+2+4) | Auto head tool ATC(C4) | LBB(Auto head tool change type) | 3-LBB stocker |
| Package A2 (1+2+3+4) | Auto head tool ATC(C4) | Package A | LBB(Manual tool change type) 1EA |
| Package A3 (1+2+3+3+4) | Auto head tool ATC(C4) | Package A | LBB(Manual tool change type) 2EA |
| Package B1** (3+4) | LBB(Manual tool change type) | 3-LBB stocker | |
| Package B2 (3+3+4) | LBB(Manual tool change type) | Package B | LBB(Manual tool change type) 1EA |
| Package B3 (3+3+3+4) | LBB(Manual tool change type) | Package B | LBB(Manual tool change type) 2EA |

* Drastically reduce LBB set-up time and optimized package for heavy-duty machining on hard materials.
** Drastically reduce LBB set-up time and high productivity package.

Tool magazine for long tool OPTION



ERGONOMIC DESIGN

Maximizes user's convenience by employing an ergonomic design concept.

Ease of machine setup through ergonomic design

By laying out the operation panel and tool magazine in a user-friendly way, tooling and workpiece setup become easier for the operator.

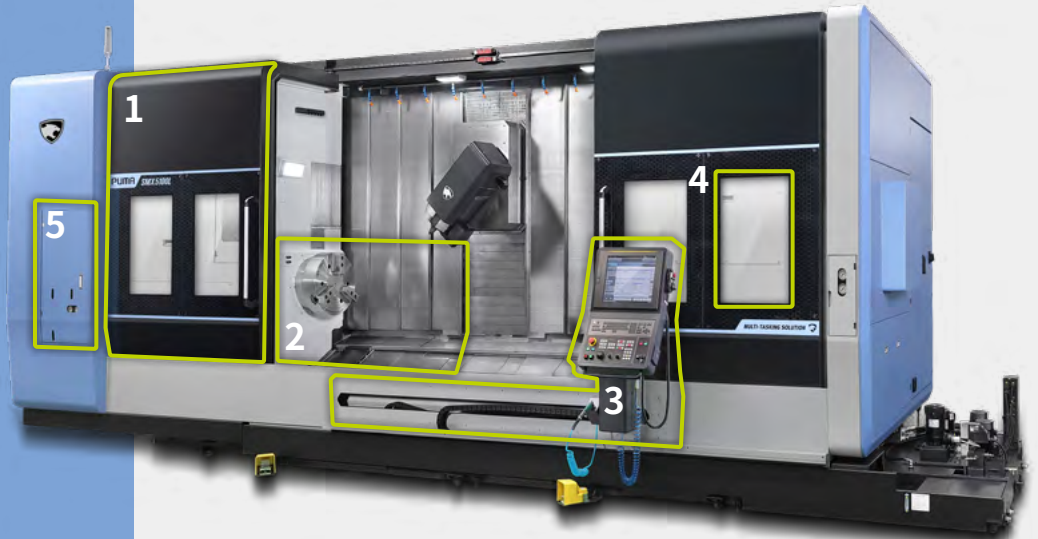

1
Wide door ensures the fast and efficient loading/unloading of workpieces using cranes etc

2
Good operator access to the spindle
Fast and comfortable work set-up

3
Operation panel with side-to-side movement, swivel action and adjustable height

Swivel angle adjustment : 100°
Height adjustment : 190 mm (7.5 inch)
Longitudinal movement : 2615 mm (103.0 inch)

4
Large front window

Enables the operator to easily monitor the machining area and operations using the front window

5
Front-focused maintenance

Device arrangement such as oil supply and gauges help facilitate daily maintenance activities



CUSTOMIZED USER-FRIENDLY FLEXIBLE OPERATION SOLUTIONS

CUFOS is a PC based control system created by DN Solutions. Equipped with intuitive user-friendly functions such as a smart phone screen and easy customization, CUFOS helps to improve operational efficiency and performance for the user.

CUFOS FEATURES

19 INCH TOUCHSCREEN

- Program memory : 2GB (40GB OPTION)
- App-based Interface like smart phone, tablet PC

EASY PROGRAMMING

- Conversational programming
- Sketch cycle : Gear skiving, Gear hobbing, Polygon turning (continuously being added...)
- SSD data server : program file sharing/ managing (CF card/USB/External PC)

EASY SET-UP/OPERATION

- Tool management for SMX
- CPS(Collision protection system)
- Manual viewer
- File manager

EASY MAINTENANCE

- Status monitor
- Alarm guidance
- Maintenance manager
- Easy connection with external S/W (creating additional App.)



CUFOS

for SMX ser.

SKETCH CYCLE

Easy and quick, but powerful programming for complex machining

Sketch cycle is easy-to-use conversational programming software that make a support to code complex shapes and machining processes such as gear skiving, hobbing and polygon turning.



Advantages

- Easy to use even for beginners with conversational programming by advising workpiece shapes, tool information and machining conditions
- Expensive CAM software is not required
- Reduce coding time by up to 70% while minimizing trial and errors
- Enable to utilize the recent high productivity processing program such as gear skiving

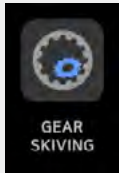

Gear skiving

Gear skiving is carried out in 5 axis machines for more flexible and productive gear machining. The complete component can be finished in one machine, which shorten production time and reduce handling and logistics cost.

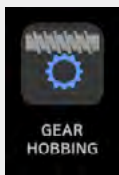
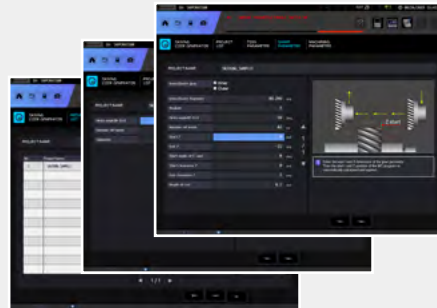

Gear hobbing

Gear hobbing make it easy to proceed gear machining with general turning centers. Gear machining programs can be created by the simple conversational programming so program coding and set-up time can be saved dramatically.

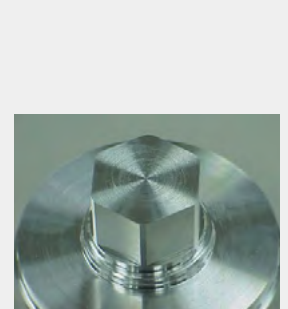
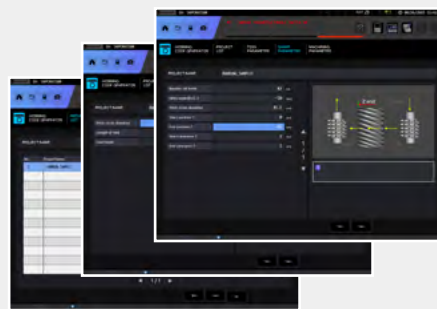

Polygon turning

Polygon turning is a machining process which allows noncircular forms (polygons) to be machine turned without interrupting the rotation of workpieces. It allows rapid production and clean machining of advanced geometries.

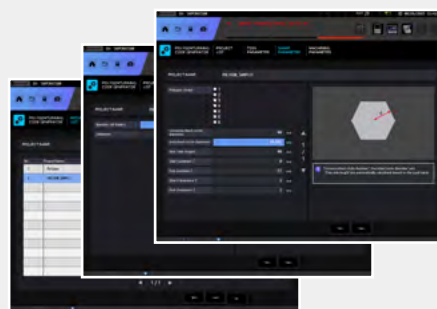

EASY SET-UP | OPERATION

Tool management, collision protection between machine unit/ workpiece/tooling and various user guidance provide higher productivity and user-convenience.



Tool management

DN Solutions EZ work tool management



Includes a summary monitoring screen and gives the operator easy access to DN Solutions's own tool management system which provides comprehensive real time data on each tool, such as remaining tool life and status of tool groups.



CPS (Collision protection system)

A function to prevent real-time collision in manual mode between the tool and equipment / machine elements inside the working area.

Use the setup manager with the CPS app to build up the machine model, and add tool, workpiece and workholding equipment details.

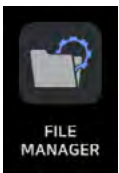
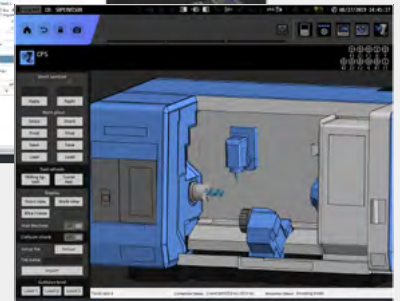
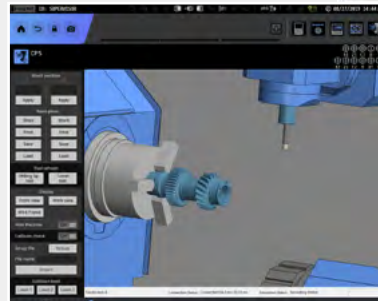
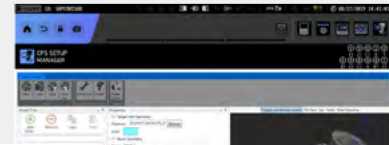

File manager

Ability to transfer various type of files including CF cards, USB memory, external PCs and memory inside CUFOS, NC programs between NC memory.



EASY MAINTENANCE

Keeping a machine in best condition through Status Monitoring, Alarm Guidance and Maintenance manager functions.

CUFOS : STANDARD | OPTIONAL SPECS

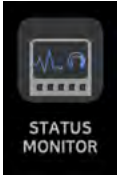

Status Monitoring

Monitoring various information such as spindle, milling spindle, feed axis, cycle time, program/tool no. on one screen.



Alarm Guidance

Presenting an operator alarm's causes and troubleshooting guides and sending an email when the alarm last for a long time.

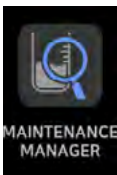
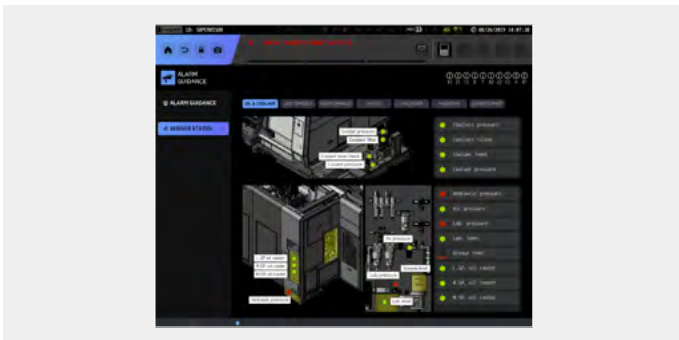

Maintenance manager

Monitors the status of machine and control elements, and confirms the alarm condition and maintenanceschedule for preventative maintenance.

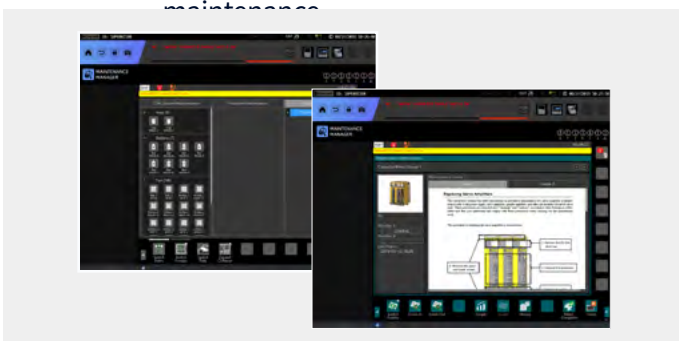

A diverse range of functions and apps are available to meet your needs.

| Description | Item | Features | SMX 5100L(B), 5100XL(B) | SMX 5100LS(B) | SMX 5100L(B), XL(B) | SMX 5100LS(B) |
|-----------------------------|---|---|--|--|---|---|
| | | | Fanuc 31i + CUFOS | Fanuc 31i + CUFOS | Fanuc 31i-5 + CUFOS | Fanuc 31i-5 + CUFOS |
| Controlled axis | Controlled axes* | | 7 (X, Z1, C, B, Y, A, {Z2}) | 8 (X, Z1, C1, B, Y, C2, A, {Z2}) | 7 (X, Z1, C, B, Y, A, {Z2}) | 8 (X, Z1, C1, B, Y, C2, A, {Z2}) |
| | Simultaneously controlled axes* | | 4 axes (Upper X, Z1, C, Y) + 1 axes (Lower {Z2}) | 4 axes (Upper X, Z1, C1, Y) + 3 axes (Lower {Z2}, C2, A) | 5 axes (Upper X, Z1, C, B, Y) + 1 axes (Lower {Z2}) | 5 axes (Upper X, Z1, C1, B, Y) + 3 axes (Lower {Z2}, C2, A) |
| Data input/output | Fast data server | | ○ | ○ | ○ | ○ |
| | Memory card input/output | | ● | ● | ● | ● |
| | USB memory input/output | | ● | ● | ● | ● |
| | SSD Data server | Part program storage size is expanded by 1GB. | ● | ● | ● | ● |
| Interface function | Embedded ethernet** | | ● | ● | ● | ● |
| | Enhanced embedded ethernet function** | | ○ | ○ | ○ | ○ |
| Operation | DNC operation | Included in RS232C interface. | ● | ● | ● | ● |
| | DNC operation with memory card | | ● | ● | ● | ● |
| | DNC operation with SSD | | ● | ● | ● | ● |
| Feed function | AI contour control I | G5.1 Q_40 Blocks | ● | ● | ○ | ○ |
| | AI contour control II | G5.1 Q_600 Blocks | ○ | ○ | ● | ● |
| Operation guidance function | EZ Guide i(Conversational programming solution) | | ● | ● | ● | ● |
| | iHMI with machining cycle*** | | ⊕ | ⊕ | ⊕ | ⊕ |
| | EZ Operation package | | ● | ● | ● | ● |
| Setting and display | CNC screen dual display function | | ● | ● | ● | ● |
| Network | FANUC MTConnect | | ⊕ | ⊕ | ⊕ | ⊕ |
| | FANUC OPC UA | | ⊕ | ⊕ | ⊕ | ⊕ |
| Others | Display unit | 15" color LCD | X | X | X | X |
| | | 19" color LCD with touch panel | ● | ● | ● | ● |
| | Part program storage size & Number of registerable programs | 1280M(512KB)_1000 programs | ● | ● | ● | ● |
| | | 2560M(1MB)_1000 programs | ○ | ○ | ○ | ○ |
| | | 5120M(2MB)_1000 programs | ○ | ○ | ○ | ○ |
| | | 10240M(4MB)_1000 programs | ○ | ○ | ○ | ○ |
| | | 20480M(8MB)_1000 programs | ○ | ○ | ○ | ○ |
| | | 2560M(1MB)_2000 programs | ○ | ○ | ○ | ○ |
| | | 5120M(2MB)_4000 programs | ○ | ○ | ○ | ○ |
| 10240M(4MB)_4000 programs | ○ | ○ | ○ | ○ | | |
| 20480M(8MB)_4000 programs | ○ | ○ | ○ | ○ | | |

● Standard ○ Optional X Not applicable ⊕ Available

*1) {Z2} axis will be supplied only with Servo Steady Rest option

*2) With 19" LCD specification, additional confirmation is required *3) Only with 19" Touch LCD standard

STANDARD | OPTIONAL SPECIFICATIONS

A range of options is available to suit individual requirements.

| Division | Option | SMX 5100L/XL | SMX 5100LB/XLB | SMX 5100LS | SMX 5100LSB | |
|---|--|--|----------------|------------|-------------|---|
| Tool shank | CAPTO C8 | ● | ● | ● | ● | |
| | HSK 100T | ○ | ○ | ○ | ○ | |
| | 10.4" operation touch panel | ● | ● | ● | ● | |
| Tool magazine | 40 tools | ● | ● | ● | ● | |
| | 80 tools | ○ | ○ | ○ | ○ | |
| | 120 tools | ○ | ○ | ○ | ○ | |
| Additional tool magazine | Long tool magazine_4ea | ○ | ○ | ○ | ○ | |
| | Automatic LBB changer package A1 or A2 or A3 | ○ | ○ | X | X | |
| | Automatic LBB changer package B1 or B2 or B3 | ○ | ○ | X | X | |
| Work holding device | Left spindle | Hydraulic chuck 15" | ● | X | ● | X |
| | | Hydraulic chuck 18" | ○ | X | ○ | X |
| | | Hydraulic chuck 21" | X | ● | X | ● |
| | | Hydraulic chuck 24" | X | ○ | X | ○ |
| | Right spindle | Hydraulic chuck 15" | X | X | ● | X |
| | | Hydraulic chuck 18" | X | X | ○ | X |
| | | Hydraulic chuck 21" | X | X | X | ● |
| | | Hydraulic chuck 24" | X | X | X | ○ |
| | Dual pressure chucking (High pressure/High pressure) | | ○ | ○ | ○ | ○ |
| | Chuck clamp & unclamp | | ● | ● | ● | ● |
| | Servo driven steady rest* | SLU5.1 (Ø85 ~ Ø350) | ○ | ○ | ○ | ○ |
| | | K5.1 (Ø100 ~ Ø410) | ○ | ○ | ○ | ○ |
| K6.0 (Ø135 ~ Ø460) | | ○ | ○ | ○ | ○ | |
| K6.1 (Ø215 ~ Ø510) | | ○ | ○ | ○ | ○ | |
| RX6.1 (Ø250-Ø685) | | ○ | ○ | ○ | ○ | |
| Coolant | T-T-C (Milling spindle) | Pressure 1.0MPa (145 psi)/Tank screen filter | ● | ● | ● | ● |
| | | Pressure 3.0MPa (435 psi)/Cyclone filter | ○ | ○ | ○ | ○ |
| | | Pressure 7.0MPa (1015 psi) / Cyclone filter | ○ | ○ | ○ | ○ |
| | Oil skimmer | ○ | ○ | ○ | ○ | |
| | Coolant pressure switch (Standard for milling spindle) | | ● | ● | ● | ● |
| Coolant level switch : Sensing level - Low | | ○ | ○ | ○ | ○ | |
| Chip disposal | Chip conveyor (Right disposal) | Hinged belt type | ○ | ○ | ○ | ○ |
| | | Magnetic scraper type | ○ | ○ | ○ | ○ |
| | | Drum filter with hinge scraper type | ○ | ○ | ○ | ○ |
| | Chip bucket | ○ | ○ | ○ | ○ | |
| | Air blower (for Left or Right spindle chuck) | ● | ● | ● | ● | |
| Chuck coolant (for Left or Right spindle chuck) | ○ | ○ | ○ | ○ | | |
| Through spindle air (for Left or Right spindle) | ○ | ○ | ○ | ○ | | |
| Through spindle coolant (Left or Right) | ○ | ○ | ○ | ○ | | |
| Through spindle air & air blower (for milling spindle) | ○ | ○ | ○ | ○ | | |
| Shower coolant(1.1kW, 165 liter/min) | ○ | ○ | ○ | ○ | | |
| Coolant gun | ○ | ○ | ○ | ○ | | |
| Air gun | ○ | ○ | ○ | ○ | | |
| Mist collector | ○ | ○ | ○ | ○ | | |
| High accuracy | Thermal compensation | ● | ● | ● | ● | |
| | Ball screw core cooling (X/Y/Z-axis) | ● | ● | ● | ● | |
| | Oil cooling flow detector(for spindle, ball screw) | ○ | ○ | ○ | ○ | |
| | Coolant chiller (temperature control) | ○ | ○ | ○ | ○ | |
| | Linear scale (X-axis) | ○ | ○ | ○ | ○ | |
| Linear scale (Y-axis) | ○ | ○ | ○ | ○ | | |
| Linear scale (Z-axis) | ○ | ○ | ○ | ○ | | |
| Measurement | Auto tool setter (Linear, Touch probe) | ○ | ○ | ○ | ○ | |
| | Auto tool setter (NC4. Laser) | ○ | ○ | ○ | ○ | |
| | Auto workpiece measurement (RMP60) | ○ | ○ | ○ | ○ | |
| | Intelligent kinematic compensation for multi-tasking (Software customized by DN Solutions) | ● | ● | ● | ● | |
| Intelligent kinematic compensation for multi-tasking (Datum Ball) | ○ | ○ | ○ | ○ | | |
| Automation | Robot interface | ○ | ○ | ○ | ○ | |
| | Automatic front door (with safety device) | ○ | ○ | ○ | ○ | |
| Others | U-axis_DANDREA TA-C160 | ○ | ○ | ○ | ○ | |
| | Air limit sensing | ○ | ○ | ○ | ○ | |
| | Auto power off | ○ | ○ | ○ | ○ | |
| | Portable MPG | ○ | ○ | ○ | ○ | |
| Rotary type window wiper | ○ | ○ | ○ | ○ | | |
| Standard accessories | Foundation bolt for anchoring | ● | ● | ● | ● | |
| | Signal tower | ● | ● | ● | ● | |
| | DN Solutions tool monitoring system | ● | ● | ● | ● | |
| | Foot switch_sigle | ● | ● | ● | ● | |

Please contact DN Solutions to select detailed steady rest specifications.

● Standard ○ Optional X Not applicable

 Fire Safety Precautions | There is a high risk of fire when using non-water-soluble cutting fluids, processing flammable materials, neglecting the controlled and careful use of coolants and modifying the machine without the consent of the manufacturer. Always check the SAFETY GUIDELINES carefully before using the machine.

PERIPHERAL EQUIPMENT

Tool setter (Automatic) OPTION

Auto linear motion type tool setter for tool measurement and tool wear detection.



Linear scales OPTION

Linear scales are ideal for high accuracy simultaneous 5-axis machining, high feed precision and machining over long periods of time.



Coolant chiller (Recommendation)

Coolant chiller is highly recommended to prevent temperature rise and minimize thermal deformation, when using a water-insoluble coolant or high-pressure coolant system of which the power is over 1.5 kw.

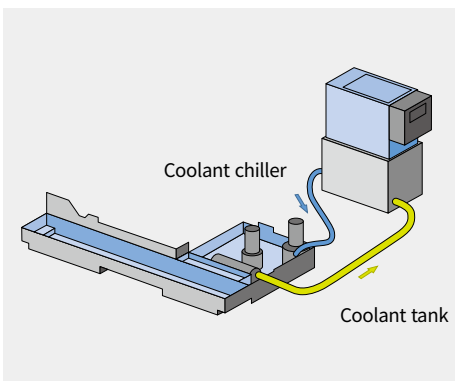

Servo driven steady rest OPTION

Steady rests support long workpieces during the machining process. Linear positioning of the steady rest is achieved by the servo motor and ball screw and can be positioned in cycle.

Steady rest parking function

When the steady rest is not being used it can be parked under the left chuck.



| Size | | Type | | | Parking function (Single) |
|--------|------------------------|--------|--------|------|---------------------------|
| | | Single | Double | Twin | |
| SLU5.1 | Ø85-Ø350 (Ø3.3-Ø3.8) | ○ | ○ | ○ | X |
| K5.1 | Ø100-Ø410 (Ø3.9-Ø16.1) | ○ | ○ | ○ | ○ (w/ 15"Chuck) |
| K6.0 | Ø135-Ø460 (Ø5.3-Ø18.1) | ○ | ○ | X | ○ (w/ 15"Chuck) |
| K6.1 | Ø215-Ø510 (Ø8.5-Ø20.1) | ○ | ○ | X | ○ (w/ 15",18" Chuck) |
| RX6.1* | Ø250-Ø685 (Ø9.8-Ø27.0) | ○ | X | X | ○ (w/ 15",18",21" Chuck) |



* RX 6.1 requires discussion with DN Solutions

Chip conveyor (Right side exit) OPTION

The conveyor provides a superior chip removal system and has a stable structure for easy maintenance and reduced leakage. By selecting the correct type of conveyor, the efficiency of the machine is increased.

| Name | Hinge belt | Magnetic scraper | Drum filter + Hinge scraper (Double type) |
|-------------|---|--|---|
| Application | For steel | For castings | For steel, castings, nonferrous metal |
| Features | <ul style="list-style-type: none"> General Appropriate for a heavy material chip of more than 30 mm in length | <ul style="list-style-type: none"> Easy maintenance Eject the chip by scraping and raising the chip with the scraper | <ul style="list-style-type: none"> For steel, castings, nonferrous metal Appropriate for both a long and a short chip - Filtering coolant |
| Shape | | | |

U-axis OPTION

D'Andrea TA-C160(Ø320mm), ID/OD/taper turning in random angles and various surface shapes is possible, while maintaining higher productivity and precise roundness.



POWER | TORQUE

SMX 5100 series

Left spindle (SMX 5100L/LS/XL)
Right spindle (SMX 5100LS)

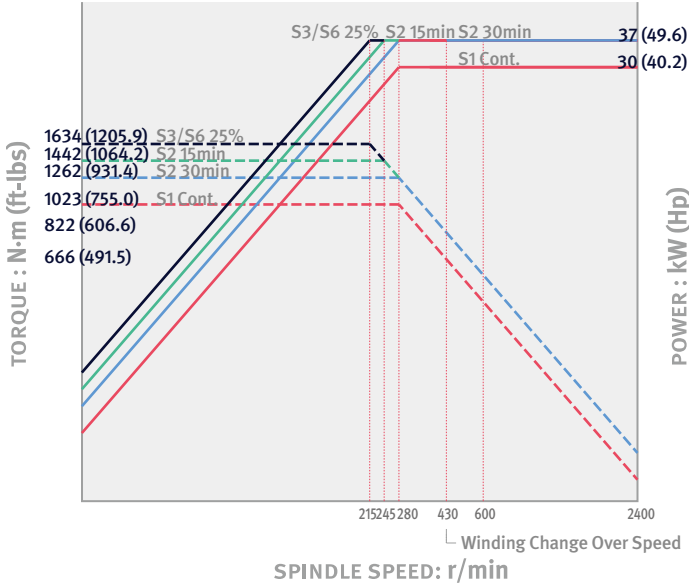

Left spindle (SMX 5100LB/LSB/XLB)
Right spindle (SMX 5100LSB)

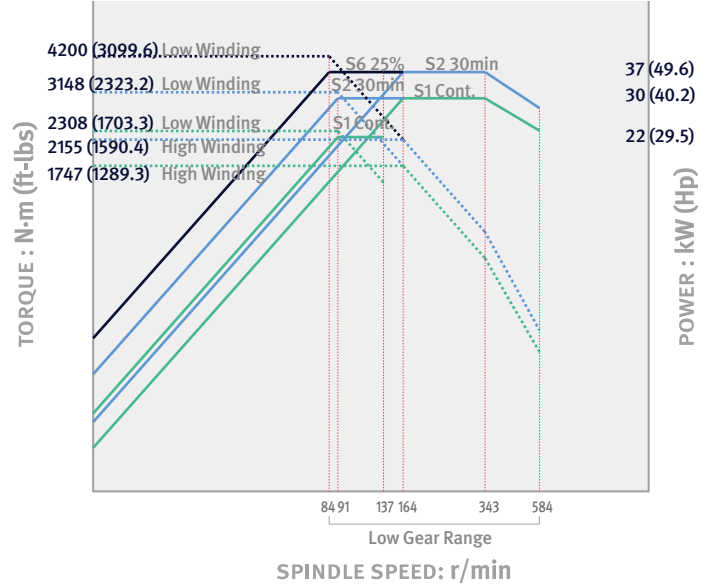

Left spindle (SMX 5100LB/LSB/XLB)
Right spindle (SMX 5100LSB)

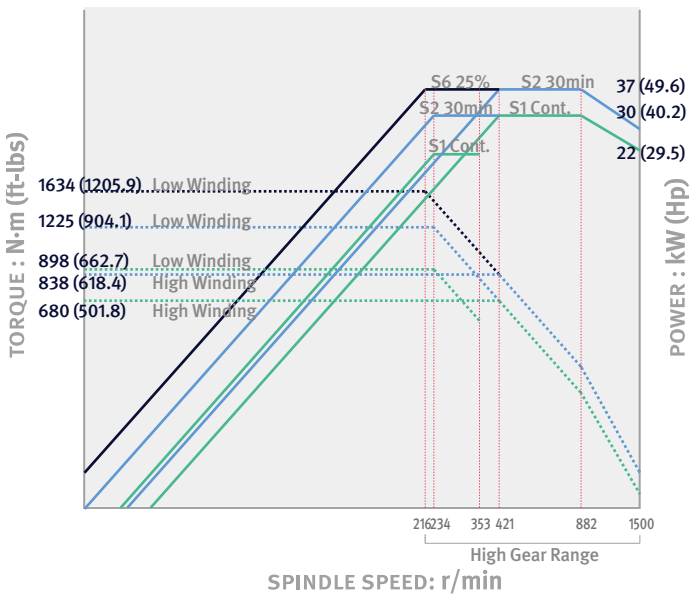

Milling spindle

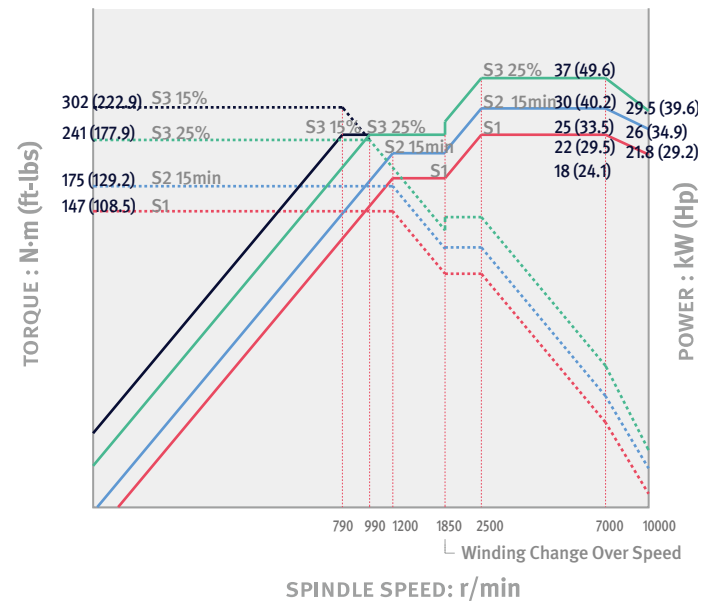

EXTERNAL DIMENSIONS

SMX 5100L / LS / LB / LSB

Unit : mm (inch)

TOP VIEW

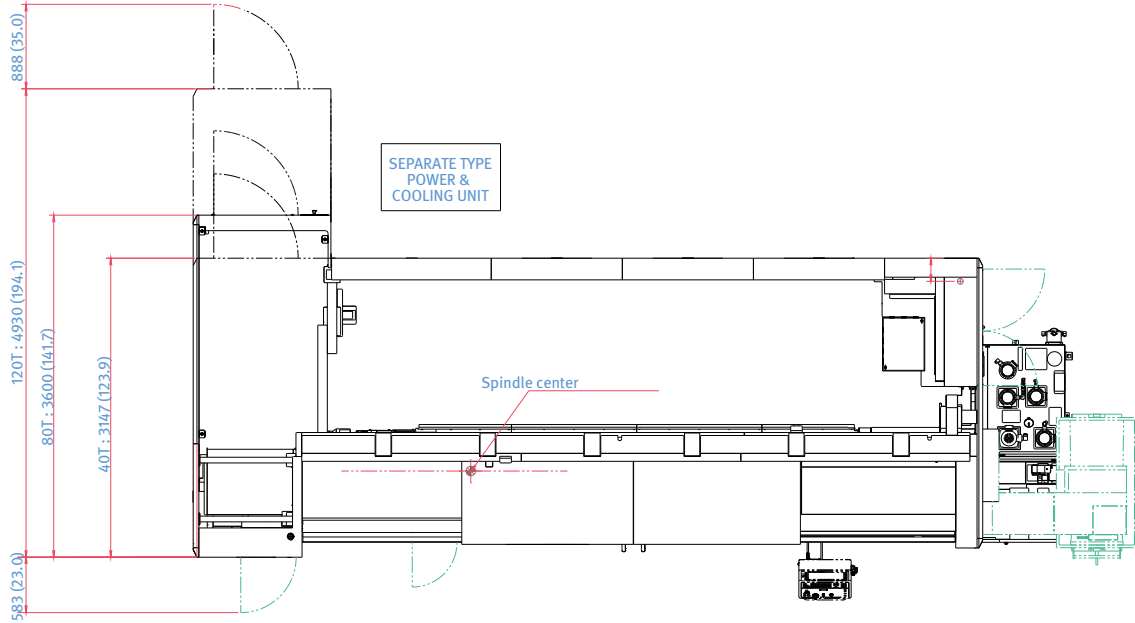

FRONT VIEW

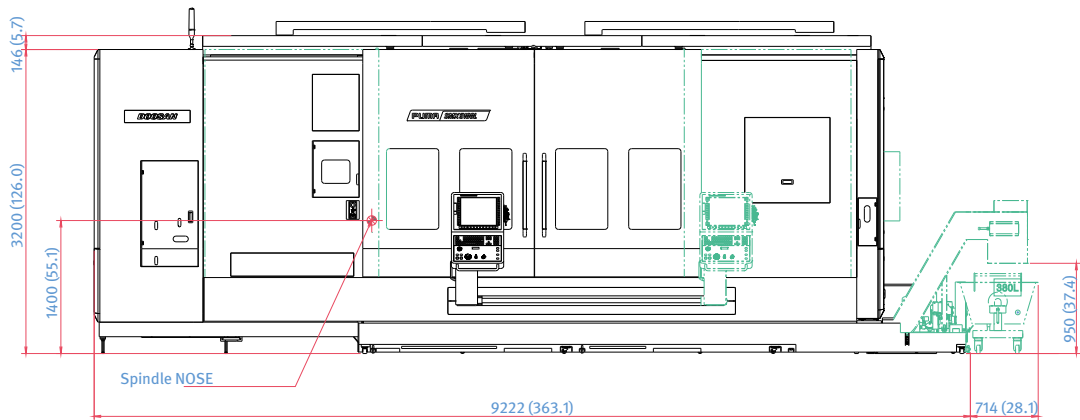

EXTERNAL DIMENSIONS

SMX 5100XL/XLB

Unit : mm (inch)

TOP VIEW

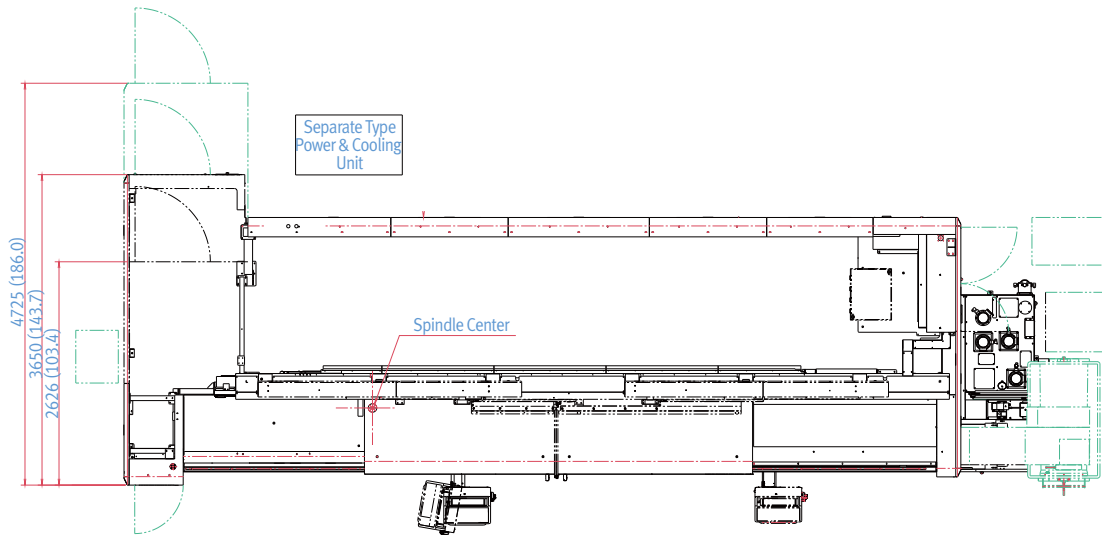

FRONT VIEW

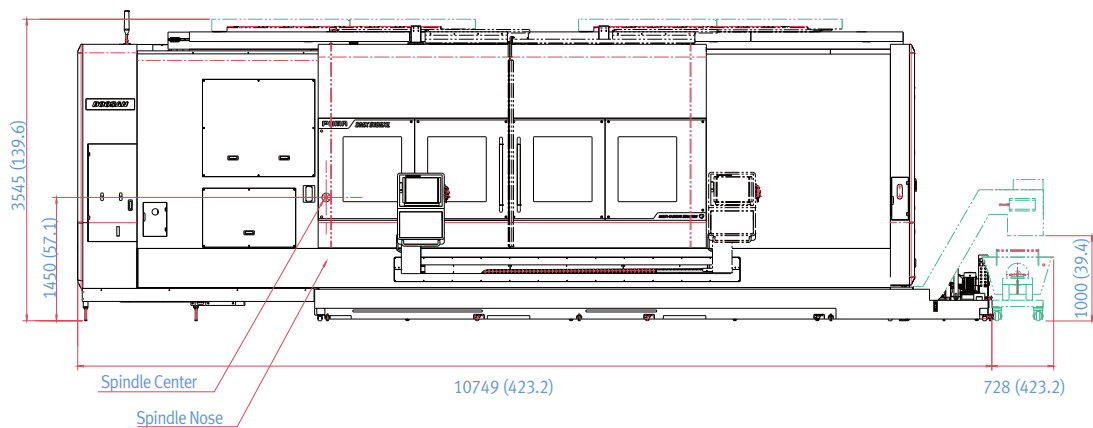

* Some peripherals can be placed in different locations.

WORKING RANGE

SMX 5100L/LB

Unit : mm (inch)

ENTIRE RANGE

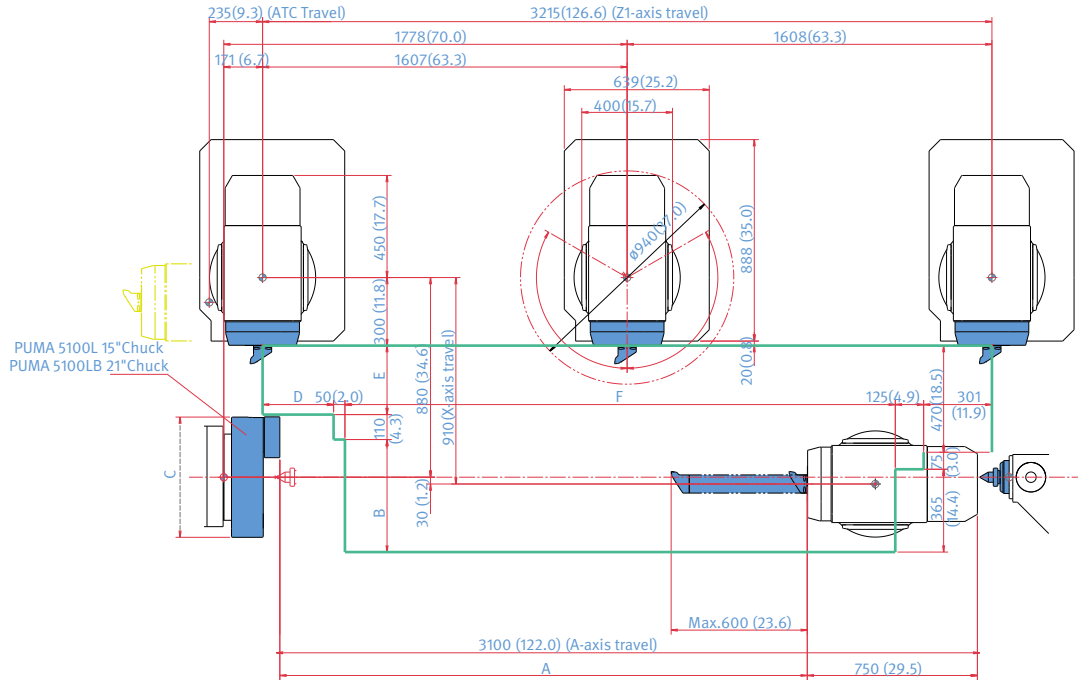

| Model | A | B | C | D | E | F |
|------------|-------------|------------|------------|------------|------------|-------------|
| SMX 5100L | 2352 (92.6) | 424 (16.7) | 381 (15.0) | 285 (11.2) | 376 (14.8) | 2454 (96.6) |
| SMX 5100LB | 2325 (91.5) | 496 (19.5) | 530 (20.9) | 313 (12.3) | 304 (12.0) | 426 (95.5) |

Y-AXIS WORKING RANGE

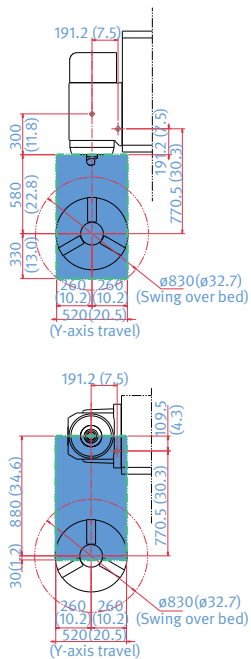

B-AXIS ROTATING RANGE

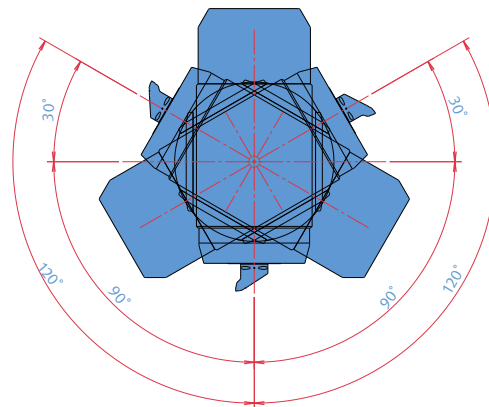

WORKING RANGE

SMX 5100XLB

Unit : mm (inch)

ENTIRE RANGE

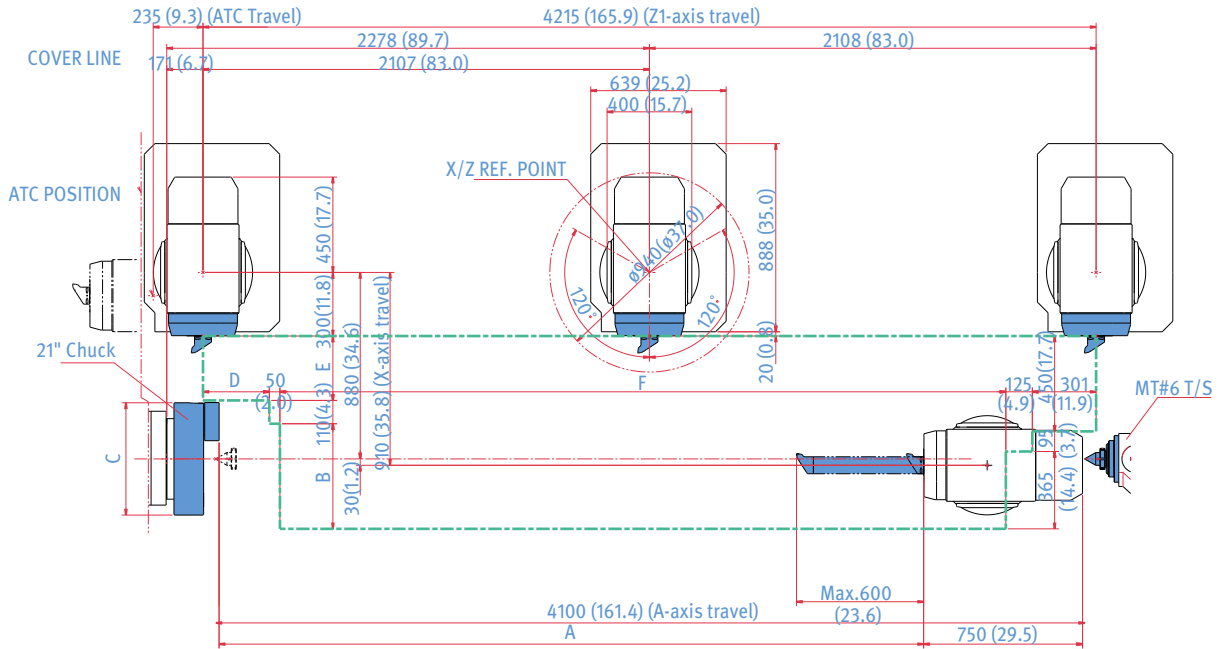

| Model | A | B | C | D | E | F |
|-------------|--------------|------------|------------|------------|------------|--------------|
| SMX 5100XLB | 3325 (130.9) | 496 (19.5) | 530 (20.9) | 313 (12.3) | 304 (12.0) | 3426 (134.9) |

Y-AXIS WORKING RANGE

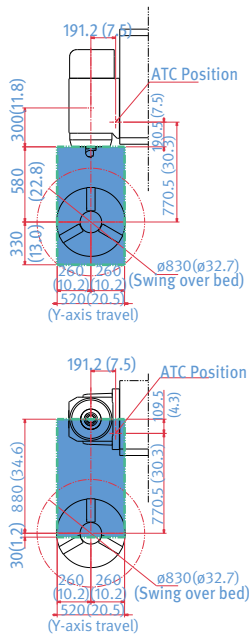

B-AXIS ROTATING RANGE

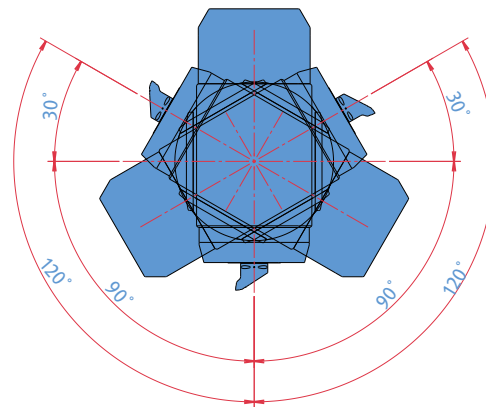

WORKING RANGE

SMX 5100LS/LSB

Unit : mm (inch)

ENTIRE RANGE

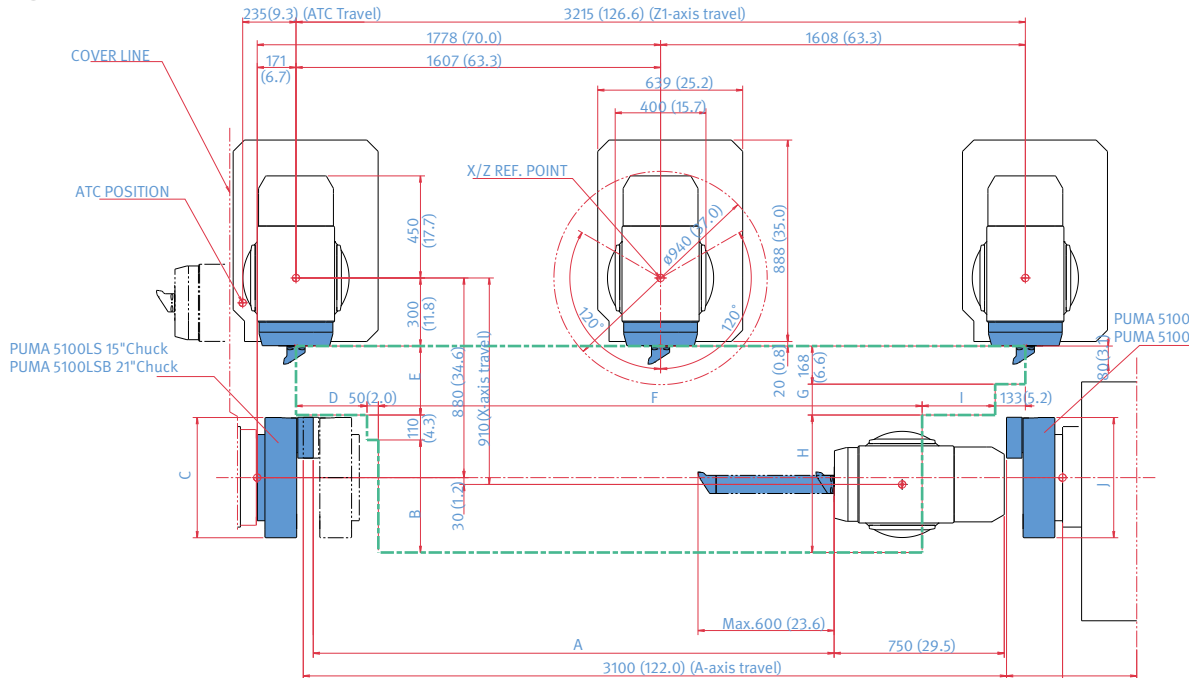

| Model | A | B | C | D | E | F | G | H | I | J |
|-------------|-------------|------------|------------|------------|------------|-------------|-----------|------------|------------|------------|
| SMX 5100LS | 2352 (92.6) | 424 (16.7) | 381 (15.0) | 285 (11.2) | 376 (14.8) | 2453 (96.6) | 208 (8.2) | 534 (21.0) | 294 (11.6) | 381 (15.0) |
| SMX 5100LSB | 2296 (90.4) | 496 (19.5) | 530 (20.9) | 313 (12.3) | 304 (12.0) | 2397 (94.4) | 136 (5.4) | 606 (23.9) | 322 (12.7) | 530 (20.9) |

Y-AXIS WORKING RANGE

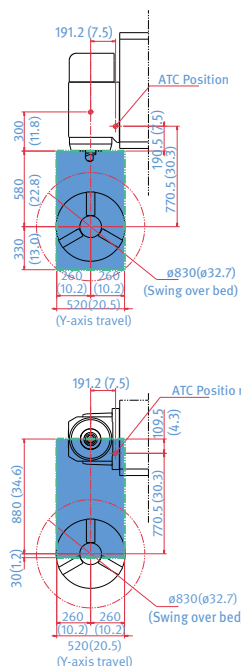

B-AXIS ROTATING RANGE

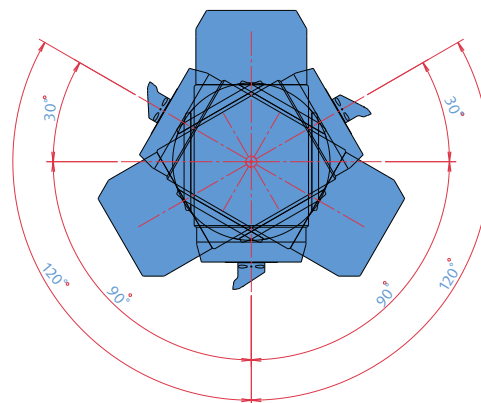

MACHINE SPECIFICATIONS

SMX 5100 series

| Item | Unit | SMX 5100L | SMX 5100LB | SMX 5100LS | SMX 5100LSB | SMX 5100XL | SMX 5100XLB | | | |
|--|--|---------------------------------|--|----------------|------------------------------------|----------------|---------------------------|----------------|--------------|--|
| Capacity | Swing over bed | mm (inch) | 830(32.7) | | | | | | | |
| | Recom. turning diameter | mm (inch) | 380(15.0) | | | | | | | |
| | Max. turning diameter | mm (inch) | 830(32.7) | | | | | | | |
| | Max. turning length | mm (inch) | 3050(120.1) | | | | 4070(160.2) | | | |
| | Chuck size | Left spindle | inch | 15 | 21 | 15 | 21 | 15 | 21 | |
| | | Right spindle | inch | - | - | 15 | 21 | - | - | |
| | Max. material weight | Flange (include chuck) | kg (lb) | 840(1851.9) | 1700(3747.8) | 840(1851.9) | 1700(3747.8) | 840(1851.9) | 1700(3747.8) | |
| Shaft (include chuck) | | kg (lb) | 1400(3086.4) | 2600(5731.9) | - | - | 1400(3086.4) | 2600(5731.9) | | |
| Bar working diameter | mm (inch) | 102(224.9) | 165.5(364.9) | 102(224.9) | 165.5(364.9) | 102(224.9) | 165.5(364.9) | | | |
| Travels | X-axis | mm (inch) | 910(35.8) (-30/+880) (-1.2/+34.6) | | | | | | | |
| | Y-axis | mm (inch) | 520(±260) (20.5(±10.2)) | | | | | | | |
| | Z-axis | mm (inch) | 3215(126.6) | | | | 4215(165.9) | | | |
| | A-axis | mm (inch) | 3100(122.0) | | | | 4100(161.4) | | | |
| | | deg | 240 | | | | | | | |
| | B-axis | deg | 360 | | | | | | | |
| | C2-axis | deg | - | 360 | | | | - | | |
| Rapid traverse rate | X-axis | m/min (ipm) | 40(1574.8) | | | | | | | |
| | Y-axis | m/min (ipm) | 40(1574.8) | | | | | | | |
| | Z-axis | m/min (ipm) | 40(1574.8) | | | | 30(1181.1) | | | |
| | A-axis | m/min (ipm) | - | 14(551.2) | | | | - | | |
| | | r/min | 30 | | | | | | | |
| | C1-axis | r/min | need consultation | 20 | need consultation | 20 | need consultation | 20 | | |
| | C2-axis | r/min | - | - | need consultation | 20 | - | - | | |
| Left spindle | Max. spindle speed | r/min | 2400 | 1500 | 2400 | 1500 | 2400 | 1500 | | |
| | Spindle motor power | kW (Hp) | 37/30 (49.6/40.2) (30min/S1 Cont.) | | | | | | | |
| | Spindle nose | ASA | A2-11 | A2-15 | A2-11 | A2-15 | A2-11 | A2-15 | | |
| | Spindle bearing diameter (Front) | mm (inch) | 180(7.1) | 240(9.4) | 180(7.1) | 240(9.4) | 180(7.1) | 240(9.4) | | |
| | Spindle through hole | mm (inch) | 120(4.7) | 185(7.3) | 120(4.7) | 185(7.3) | 120(4.7) | 185(7.3) | | |
| | Min. spindle indexing angle (C1-axis) | deg | 0.0001 | | | | | | | |
| Right spindle | Max. spindle speed | r/min | - | - | 2400 | 1500 | - | | | |
| | Spindle motor power | kW (Hp) | - | - | 37/30 (49.6/40.2) (30min/S1 Cont.) | - | - | | | |
| | Spindle nose | ASA | - | - | A2-11 | A2-15 | - | | | |
| | Spindle bearing diameter (Front) | mm (inch) | - | - | 180(7.1) | 240(9.4) | - | | | |
| | Spindle through hole | mm (inch) | - | - | 120(4.7) | 185(7.3) | - | | | |
| | Min. spindle indexing angle (C2-axis) | deg | - | - | 0.0001 | | - | | | |
| Milling spindle | Max. spindle speed | r/min | 10000 | | | | | | | |
| | Milling spindle motor power | kW | 37/30/25 (49.6/40.2/33.5) (2.5min/30min/Cont.) | | | | | | | |
| | Min. spindle indexing angle (B-axis) | deg. | 0.0001 | | | | | | | |
| Automatic tool changer | No. of tool stations | ea | 40 {80,120} | | | | | | | |
| | Tool shank | | CAPTO C8 | | | | | | | |
| | Max. tool | Diameter continuous | mm (inch) | 135(5.3) | | | | | | |
| | | Diameter without adjacent tools | mm (inch) | 260(10.2) | | | | | | |
| | Max. tool length | mm (inch) | 600(23.6) | | | | | | | |
| | Max. tool weight | kg (lb) | 30(66.1) | | | | | | | |
| | Max. tool moment | N·m (ft-lbs) | 29.4(21.7) | | | | | | | |
| Tool change time (T-T-T) | Tool-to-Tool | s | 2.4 | | | | 2.6 | | | |
| | Chip-to-Chip | s | 13.2 | | | | 18.2 | | | |
| Long tool magazine | Max. tool storage capacity | ea | 4 | | | | | | | |
| | Max. tool size | mm (inch) | Ø80 x 1120 (Ø3.1 x 44.1) | | | | | | | |
| | Max. tool weight | kg (lb) | 70(154.3) | | | | | | | |
| Automatic LBB(Long boring bar) changer | Max. tool storage capacity | ea | 3 | - | - | - | 3 | | | |
| | Max. tool size | mm | Ø100 x 1000 (Ø3.9 x 39.4) | | | | Ø100 x 1000 (Ø3.9 x 39.4) | | | |
| | Max. tool weight (Boring bar holder) | kg (lb) | 140(308.6) | | | | 140(308.6) | | | |
| | Auto Head tool change (for Long Boring Bar Type) | Max. tool storage capacity | ea | 10 | | | | 10 | | |
| | | Head tool type | | CAPTO C4 | | | | CAPTO C4 | | |
| | Max. tool size | mm (inch) | 75(3.0) | | | | 75(3.0) | | | |
| kg (lb) | | 1 | | | | 1 | | | | |
| Tail Stock | Quill bore taper | MT | #5 | | | | #6 | | | |
| | Tail stock travel | mm (inch) | 3100(122.0) | | | | 4100(161.4) | | | |
| Powersource | Electric power supply (rated capacity) | kVA | 95.73 | 98.63 | 118.50 | 121.68 | 96.01 | 98.92 | | |
| Machine dimensions | Height | mm (inch) | 3346(131.7) | 3346(131.7) | 3346(131.7) | 3346(131.7) | 3398(133.8) | 3398(133.8) | | |
| | Length | mm (inch) | 9222(363.1) | 9222(363.1) | 9522(374.9) | 9522(374.9) | 10749(423.2) | 10749(423.2) | | |
| | Width | mm (inch) | 3597(141.6) | 3597(141.6) | 3597(141.6) | 3597(141.6) | 3597(141.6) | 3597(141.6) | | |
| | Weight | kg (lb) | 31000(68342.3) | 33000(72751.5) | 32200(70987.8) | 35900(79144.8) | 37000(81569.8) | 39000(85979.0) | | |
| Control | NC system | CUFOS(Fanuc base) | | | | | | | | |

The DN Solutions promise, MACHINE GREATNESS, has two important meanings. The first is simple: DN Solutions makes great machines. The second is a challenge to our end-users. With a product line that is this comprehensive, accurate and reliable, we equip our customers to machine greatness. **The big question: *Why should you choose DN Solutions over other options?***

Here's why...



**MACHINE
GREATNESS™**



WHAT YOU MAKE AND HOW YOU MAKE IT MATTERS—SO MAKE IT
GREAT WITH DN SOLUTIONS.

UNBEATABLE MACHINES

You won't find a more comprehensive range or a better combination of value, performance and reliability anywhere else.

ROBUST PRODUCT LINE

We offer an impressive range of machine models and hundreds of configurations. Whatever your machining needs and requirements, there's a DN Solutions for you.

READILY AVAILABLE - ANYWHERE IN THE WORLD

Machining centres (including 5-axis machines), lathes, multi-tasking turning centres and mill-turn machines, and horizontal borers with best-in-class specifications are all available...ready to install.

EXPERT SERVICE

Our dedicated, experienced and knowledgeable team is totally committed to improving your productivity, growth and success.

RESPONDING TO CUSTOMERS ANYTIME, ANYWHERE

DN Solutions Global Network

DN Solutions provides systems-based professional support services, before and after the machine tool sale, by responding quickly and efficiently to customers. By supplying spare parts, product training, field service and technical support, we provide the expert care, attention and assistance our customers expect from a market leader.

| | | | |
|--|-----------------|------------|---|
| Global sales and service support network | | 51 | Technical centers Technical center, Sales support, Service support, Parts support |
| 4 | Corporations | 200 | Service posts |
| 156 | Dealer networks | 3 | Factories |



CUSTOMER SUPPORT AND SERVICES

We're there for you whenever you need us.

We help our customers operate at maximum efficiency by providing them with a range of tried, tested and trusted services - from pre-sales consultancy to post-sales support.



Field services

- On-site service
- Machine installation and testing
- Scheduled preventive maintenance
- Machine repair service



Parts supply

- Supplying a wide range of original DN Solutions spare parts
- Parts repair service



Training

- Programming, machine setup and operation
- Electrical and mechanical maintenance
- Applications engineering



Technical support

- Supports machining methods and technology
- Responds to technical queries
- Provides technical consultancy



dn-solutions.com

Head Office

22F T Tower, 30, Sowol-ro 2-gil
Jung-gu, Seoul, Korea, 04637

Tel: +82-2-6972-0370/0350
Fax: +82-2-6972-0400

DN Solutions America

19A Chapin Road, Pine Brook
New Jersey 07058, United States

Tel: +1-973-618-2500
Fax: +1-973-618-2501

DN Solutions Europe

Emdener Strasse 24, D-41540
Dormagen, Germany

Tel: +49-2133-5067-100
Fax: +49-2133-5067-111

DN Solutions India

No.82, Jakkuar Village
Yelahanka Hobli, Bangalore-560064

Tel: + 91-80-2205-6900
E-mail: india@dncompany.com

DN Solutions China

Room 101,201,301, Building 39 Xinzhuan
Highway No.258 Songjiang District
China Shanghai (201612)

Tel: +86 21-5445-1155
Fax: +86 21-6405-1472

Sales inquiry

sales@dncompany.com

* For more details, please contact DN Solutions.

* Specifications and information contained within this catalogue may be changed without prior notice.